

HP Print Server Appliance 4250

Innovative network print appliance optimized to host print spooling and services



Streamline network printing, print driver distribution, and print management. The cost-effective HP Print Server Appliance 4250 (PSA) manages all aspects of network printing by off-loading printing traffic from the general server, so you spend less time managing the network while receiving more reliable and increased printer uptime.

Key reasons to buy

- **Simple to operate**
- **Streamlines network management**
- **Delivers a cost-effective solution**

Ease of use

- **Add new printers and print shares**
- **Distribute printer drivers to client PCs**
- **Manage print queues and print shares**

Simplifies management

- **Manage shared office printers right from your desk.** With HP Web Jetadmin 7.5, the PSA allows you to remotely manage and monitor print jobs, troubleshoot problems, reboot the system, and install firmware upgrades.
- **Easily update and distribute printer drivers to network PCs.** Fleet management via HP Web Jetadmin 7.5 allows easy addition, deletion, distribution, and management of all printer drivers in one easy step: update one PSA; printer drivers are automatically distributed to all network PSAs and then to each client PC.

Streamlines printing

- **Improve printing functionality and reliability.** Gain more control and reduce support by localizing network print traffic. Free general servers from handling print jobs and allow them to conduct other critical tasks.
- **Save time when updating drivers.** The PSA's fleet management capabilities let you manage all aspects of driver installation from a single location rather than servicing individual PCs.
- **Implement a robust server for all of your office printers.** Features such as the 20 GB hard drive allow you to connect up to 50 printers and 300 clients to a single PSA that supports both HP-brand printers as well as printers from other manufacturers.

Saves money

- **Reduce printing's total cost of ownership.** PSAs are less expensive to buy than general servers, reduce overall IT costs, and do not require licensing fees.
- **Keep your employees productive even when the general-purpose server is down.** Since all printing is routed through the PSA, your office keeps working even if the general WAN server is temporarily offline.

HP print server appliances are designed to increase the manageability, performance, and reliability of business printing while reducing the total cost of ownership. HP servers, printers, accessories, digital solutions, and services are designed together to work together and invented to meet your business needs.

Many companies are turning to HP print server appliances to optimize their network and receive substantial time and cost savings.

- A large financial institution has used the appliance to stabilize its environment during an NOS migration.
- A prominent women's apparel manufacturer uses the appliance to increase uptime for mission-critical business printing needs.
- A large telecommunications firm has turned to the appliance to replace expensive servers and save money, as well as to protect remote offices from losing printing when the WAN goes down.
- A large financial institution reduced help desk calls by more than 50 percent.

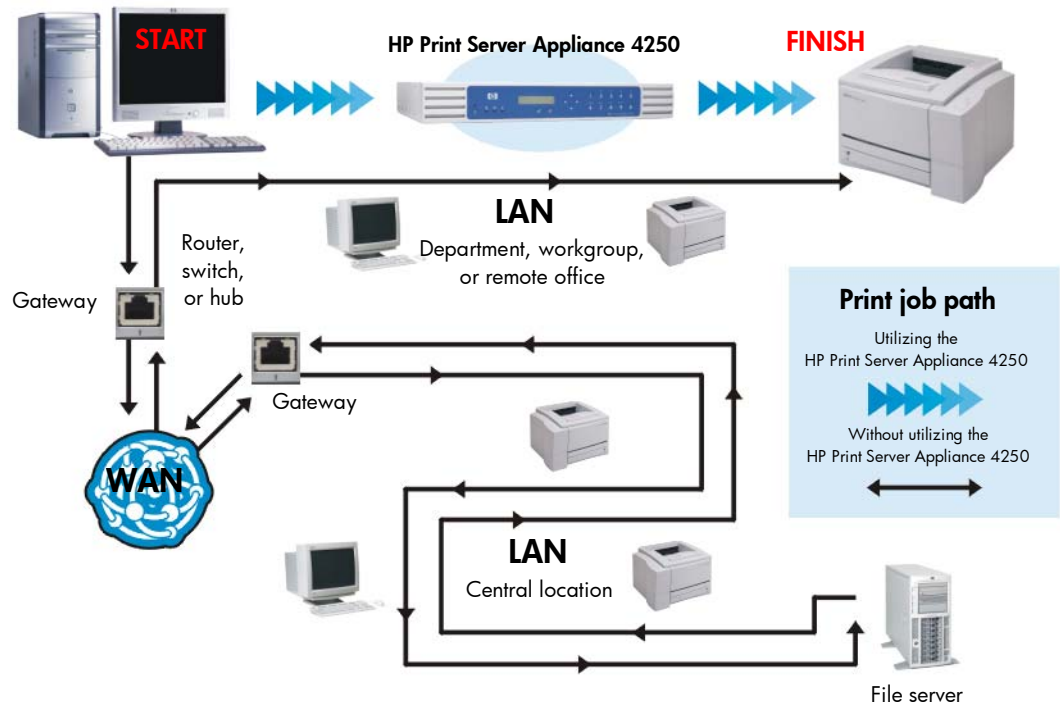

For the network administrator

Use a common Web browser to remotely manage any number of HP print server appliances with HP Web Jetadmin 7.5.

- Manage print jobs
- Monitor print jobs
- Troubleshoot problems
- Install firmware upgrades
- Reboot the system
- Manage drivers

For clients

- Print even when the WAN link or file server is down.
- Experience faster, more reliable printing and increased printer up-time.
- No need to worry about drivers.
- Eliminate network slowdown with up to 17 GB spooling capacity.

A simple, efficient, cost-effective solution.

“This new class of appliance servers, known as Print Server Appliances, is worthy of consideration for companies that are adding or upgrading server capacity. Print Server Appliances offer benefits beyond those offered by generic servers, including lower costs (e.g., hardware, NOS licensing, training, maintenance, and support), faster installation and time to print, and easier troubleshooting and remote management adding or upgrading server capacity.”

International Data Corporation (IDC)

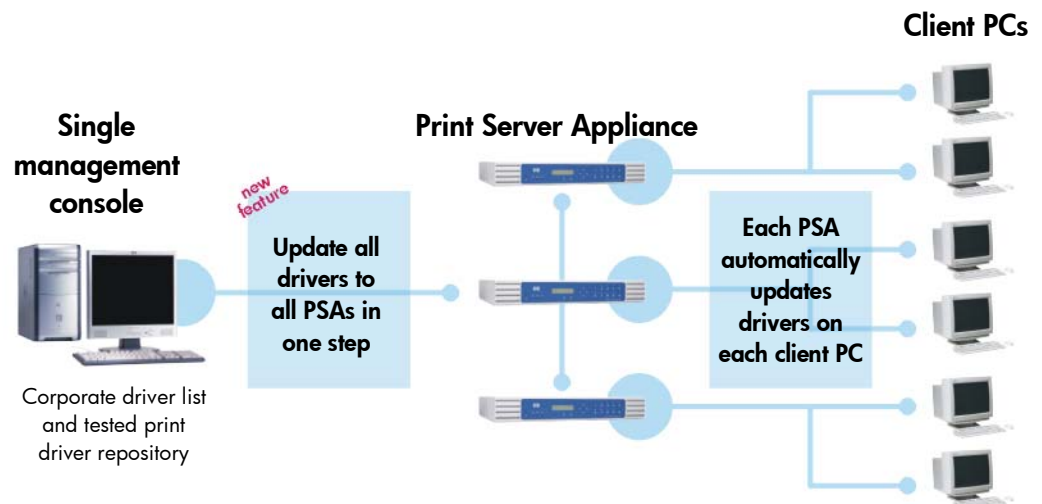

Fleet management via HP Web Jetadmin 7.5

- Update one PSA with new printer drivers; the drivers are automatically distributed to all network PSAs and then to each client PC
- Queue management
- Status and utilization management tools
- New server migration tools
- Update firmware

Top to bottom driver distribution

- Effective solution for preventing data disasters
- Saves time

Free firmware updates

Use HP Web Jetadmin 7.5 to upgrade the firmware for the HP Print Server Appliance 4250. Go to: www.hp.com/go/webjetadmin.

HP Print Server Appliance 4250

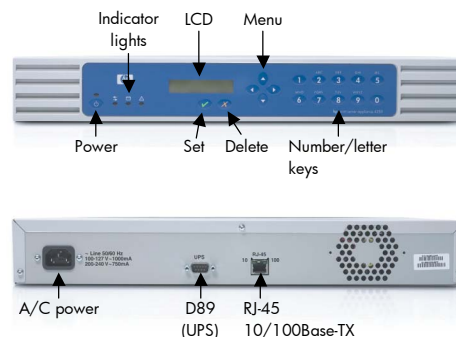

Technical specifications

Integrated technology	The HP Print Server Appliance 4250 includes software developed by: <ul style="list-style-type: none"> The University of California, Berkeley and its contributors The Apache Group for use in the Apache HTTP Server Project (www.apache.org) The GNU Project (www.gnu.org), and other open source developers
Minimum processor speed	300 MHz Cyrix
Hard drive	20 GB
Largest spoolable file size	2 GB
Spooling capacity	Up to 17 GB
Memory	128 MB RAM
Supported browsers	Microsoft Internet Explorer 5.5, 6.0 or later; Netscape 6.2 or later
Supported printers and clients	All LPD-enabled network printers and print servers/internet connectors are supported
Connectivity	
Interfaces	RJ-45 port for 10/100Base-TX unshielded twisted-pair cable, DB9 port for UPS support
Network operating systems	Microsoft® Windows® 95, 98, Millennium (Me), NT 4.0, 2000, and XP; UNIX® (HP-UX, Solaris, AIX, Linux); and LPD-compatible mainframe systems (Printing from Macintosh systems is currently not supported.)
Network protocols supported	TCP/IP
Network types	Ethernet/802.3, RJ-45 10/100Base-TX
Dimensions (w by d by h)	17 by 13 by 2.4 in (441 by 323 by 63 mm); fits into a standard 19-inch equipment rack
Weight	10 lb (22.27 kg)
What ships in the box	HP Print Server Appliance 4250, 3 Quick Start posters (English/Spanish, French/German, Italian/Portuguese), documentation CD-ROM, rack-mount kit, power cable

Environmental ranges

Operating temperature:	41 to 104 degrees F (5 to 40 degrees C)
Storage temperature:	-38 to 158 degrees F (-38.9 to 70 degrees C)
Operating humidity:	15 to 80 percent relative humidity

Acoustics

5.2 B(A)

Power requirements

120/240 VAC at 50/60 Hz

Power consumption

100-127 V:	1000mA
200-240 V:	750mA

Power connection

IEC-320

Power certifications

Safety:	UL, ULc, CE
EMC:	FCC Part 15 Class A, CISPR-22 Class A (1993), ICES-003 Class A, AS/NZS 3548 Class A, EN55024 (1998), EN61000-3-2, EN61000-3-3

Warranty

Technical support and limited one-year express exchange warranty (FedEx priority overnight, next business day).
Optional warranty available (2-year, express exchange SupportPack).

ENERGY STAR® is a U.S. registered service mark of the United States Environmental Protection Agency. As an ENERGY STAR partner, HP has determined that this product meets the guidelines for energy efficiency. HP-UX Release 10.20 and later and HP-UX Release 11.00 and later (in both 32 and 64-bit configurations) on all HP 9000 computers are Open Group UNIX 95 branded products. Microsoft®, Windows, and Windows NT are U.S. registered trademarks of Microsoft Corp, Inc. Netscape is a U.S. trademark of Netscape Communications Corporation. UNIX® is a registered trademark of the Open Group. All other brand and product names are trademarks or registered of their respective companies.

© 2004 Copyright Hewlett Packard Development Company, L.P. Reproduction, adaptation, or translation without prior written permission is prohibited, except as allowed under the copyright laws.

The information contained herein is subject to change without notice. The only warranties for HP products and services are set forth in the express warranty statements accompanying such products and services. Nothing herein should be construed as constituting an additional warranty. HP shall not be liable for technical errors or omissions contained herein.



5981-6564ENUC

Ordering information

Product	Number
HP Print Server Appliance 4250	J7941A
HP Web Jetadmin 7.5	J6052AA
HP SupportPack, 2-year, express exchange	J7941A 22L

To order the HP Print Server Appliance 4250, compare it to other products, or view its features, go to: www.hp.com/go/printappliance

For technical support for HP Print Server Appliances, go to: www.hp.com/go/psa

To obtain a free download of HP Web Jetadmin 7.5, go to: www.hp.com/go/webjetadmin

HP Jetdirect products offer a variety of printer-sharing solutions for both network and non-network environments. Easy to connect, they provide a simple, reliable way to share printers. For more information, visit: www.hp.com/go/jetdirect

For information about HP Jetdirect product support, visit HP Customer Care online; go to: www.hp.com/support/net_printing

HP peripherals, personal computers, supplies, and accessories are available at authorized HP resellers worldwide. In North America, call for the authorized HP reseller nearest you:

United States: 1-800-243-9812
Outside United States: 1-208-344-4809

